

**Congratulations on selecting the MRM400™ from
RCA Communications Systems - *The Most Trusted Name In Radio!***

Our new series of business communications products establishes a new benchmark in premium radio products made to perform flawlessly under the most demanding commercial conditions. Cutting edge design, professional grade materials and components, simple operation and superior assembly quality - RCA Communications Systems has it all, including our exclusive no-nonsense, two-year "Warranty Protection Program," one of the most comprehensive warranties in the communications industry.

To ensure maximum performance from your MRM400™ radio, please be sure to carefully read this manual.

CAUTION:

- Never use the Distress call unless you are in an emergency.
- Do not use or place the transceiver in areas of heat, humidity and dust.
- The working voltage for the transceiver is 13.8V. If the power source is 24V, please use a power converter (24V converted to 13.8V), or the transceiver won't work.
- Never directly connect to 220V AC as this will ruin the transceiver. If an abnormal odor or smoke is detected coming from the transceiver, turn off the power immediately.
- Do not transmit before connecting the antenna. This will ruin the transceiver.
- After extended use, the heating panel will become hot, which is normal.

FOREWORD

Thank you for purchasing our MRM400 Marine 2-Way Radio.

The MRM400 VHF Marine Two-Way Radio is a powerful marine radio that is designed to IMO (International Maritime Organization) standards. The radio uses state-of-the-art technology and with proper care, should provide you with years of trouble-free operation.

FEATURES

- Advanced receiver performance
- Easy-to-hear speaker
- Built-in DSC (Digital Select Calling) can be connected with a GPS (sold separately)
- Rugged waterproof construction

- Favorite channel function
- WaterClean water draining function

IMPORTANT

READ ALL INSTRUCTIONS carefully and completely before using the transceiver.

SAVE THIS INSTRUCTION MANUAL - This instruction manual contains important operating instructions you will want to refer to at a later date.

IN CASE OF EMERGENCY

If your vessel requires emergency assistance, contact other vessels and the Coast Guard by sending a distress call on Channel 16.

DISTRESS CALL PROCEDURE USING CHANNEL 16

1. "MAYDAY MAYDAY MAYDAY."
2. "THIS IS" (name of vessel)
3. Your call sign or other indication of the vessel (AND 9-digit DSC ID if you have one).
4. "LOCATED AT" (your position)
5. The nature of the distress and assistance required.
6. Any other information which might facilitate a rescue.

Or, transmit your distress call using Digital Selective Calling on Channel 70.

DISTRESS CALL PROCEDURE USING DIGITAL SELECTIVE CALLING (DSC) CHANNEL 70

1. While lifting up the key cover, hold down

[DISTRESS] for 3 seconds until you hear 3 short beeps change to one long beep.

2. Wait for an acknowledgment on Channel 70 from a coast station.
 - After the acknowledgment is received, Channel 16 is automatically selected.
3. Hold down [PTT], then transmit the appropriate information as listed above.

PRECAUTIONS

■ **WARNING! NEVER** connect the transceiver to an AC outlet. This may pose a fire hazard or result in an electric shock.

■ **WARNING! NEVER** connect the transceiver to a power source of more than 16 V DC or use reverse polarity. This will could cause a fire the transceiver.

WARNING! NEVER cut the DC power cable between the DC plug at the back of the transceiver and fuse holder. If an incorrect connection is made after cutting, the transceiver may be damaged.

CAUTION: NEVER place the transceiver where normal operation of the vessel may be hindered or where it could cause bodily injury.

KEEP the transceiver and microphone at least 3.3 feet (1 meter) away from your vessel's magnetic navigation compass.

DO NOT use or place the transceiver in areas with temperatures below -4°F (-20°C) or above 140°F (+60°C), or in areas subject to direct sunlight, such as the dashboard.

DO NOT use harsh solvents such as benzine or alcohol to clean the transceiver, as they will damage the transceiver's surfaces. If the transceiver becomes dusty or dirty, wipe it clean with a soft, dry cloth.

BE CAREFUL! The transceiver rear panel will become hot when operating continuously for long periods of time.

Place the transceiver in a secure place to avoid inadvertent use by children.

RCA requires the radio operator to meet the FCC Requirements for Radio Frequency Exposure. An omnidirectional antenna with gain not greater than 9 dBi must be mounted a minimum of 16 1/2 feet (5 meters), measured from the lowest point of the antenna, vertically above the main deck and all possible personnel. This is the minimum safe separation distance estimated to meet all RF exposure compliance requirements. The 16 feet (5 meter) distance is based on the FCC Safe Maximum Permissible Exposure (MPE) distance of 10 feet (3 meters) added to the height of an adult, 6 feet (2 meters), is appropriate for all vessels.

For watercraft without suitable structures, the antenna must be mounted so as to maintain a minimum of 3 feet (1 meter) vertically between the antenna, (measured from the lowest point of the antenna), to the heads of all persons AND all persons must stay outside of the 10 foot (3 meter) MPE radius.

Do not transmit with radio and antenna when persons are within the MPE radius of the antenna, unless such persons (such as driver or radio operator) are shielded from antenna field by a grounded metallic barrier. The MPE Radius is the minimum distance from the antenna axis that person should maintain in order to avoid RF exposure higher than the allowable MPE level set by FCC.

FAILURE TO OBSERVE THESE LIMITS MAY ALLOW THOSE WITHIN THE MPE RADIUS TO EXPERIENCE RF RADIATION ABSORPTION WHICH EXCEEDS THE FCC MAXIMUM

PERMISSIBLE EXPOSURE (MPE) LIMIT.

IT IS THE RESPONSIBILITY OF THE RADIO OPERATOR TO ENSURE THAT THE MAXIMUM PERMISSIBLE EXPOSURE LIMITS ARE OBSERVED AT ALL TIMES DURING RADIO TRANSMISSION. THE RADIO OPERATOR IS TO ENSURE THAT NO BYSTANDERS COME WITHIN THE RADIUS OF THE MAXIMUM PERMISSIBLE EXPOSURE LIMITS.

Determining MPE Radius

THE MAXIMUM PERMISSIBLE EXPOSURE (MPE) RADIUS HAS BEEN ESTIMATED TO BE A RADIUS OF ABOUT 10 FEET (3M) PER OET BULLETIN 65 OF THE FCC.

THIS ESTIMATE IS MADE ASSUMING THE MAXIMUM POWER OF THE RADIO AND ANTENNAS WITH A MAXIMUM GAIN OF 9dBi ARE USED FOR A SHIP MOUNTED SYSTEM.

CONTENTS

PREPARATION	
Supplied Accessories.....	8
Transceiver Mounting	8
Antenna Connection.....	10
Connections	10
Dimensions	12
PANEL DESCRIPTION	
Front Panel	12
Microphone	14
Function Display.....	15
BASIC OPERATION	
Power ON/OFF	17
Receiving and Transmitting	17
Channel Group Selection	17
Channel Selection	19
Call Channel Programming	20
Channel Comments	21
Microphone Lock Function	22
Display Backlighting	23
WaterClean Water Draining Function	23
SCAN OPERATION	
Scan Types	23
Setting TAG Channels	24
DUALWATCH / TRI-WATCH	
Description.....	26
Operation	26
DSC OPERATION	
MMSI Code Programming	27
MMSI Code Check	27
DCS Address ID.....	28
Distress Call	30

CONTENTS [continued]

Individual Call	32
Group Call	36
All Ships Call	38
Geographical Area Call	40
Position Indication Call	40
SET MODE	
Set Mode Programming	45
Set Mode Items	47
CHANNEL LIST	49
SPECIFICATIONS	50
TROUBLESHOOTING	52
WARRANTY STATEMENT	54
RF EXPOSURE	57

PREPARATION

SUPPLIED ACCESSORIES

The following accessories are supplied:

Items	Qty.
DC power cable	1
Spare fuse	1
Mounting bracket	1
Screws/lock washers	2
Microphone hanger	1
Instruction manual	1
Knob Bolts and flat washers	2
Screws for Microphone Hanger	2

TRANSCEIVER MOUNTING WITH SUPPLIED MOUNTING BRACKET

■ The universal mounting bracket supplied with your transceiver allows overhead or dashboard mounting.

1. Fix the mounting bracket to shelf or dashboard with the supplied screws and lock washers. Mount the transceiver to the mounting bracket with the knob bolts and washers.
2. Mount the transceiver so the face of the unit can easily be seen when in use. Place the flat washers on the knob bolts and tighten the knob bolts so that the transceiver is securely mounted.

- You may use a spongy cushion between the transceiver and mounting bracket to reduce vibration.

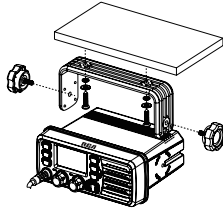

■ Embedded mounting

1. Cut a hole into the instrument panel or wherever you plan to mount the transceiver.
2. Slide the transceiver through the holes as shown below.

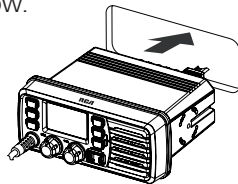

3. Attach the clamps on either side of the transceiver with 2 supplied bolts.

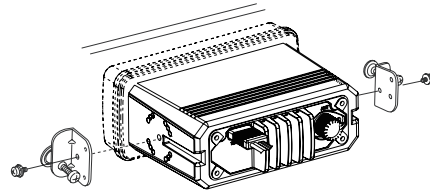

4. Tighten the end bolts on the clamps so that the clamps press firmly against the inside of the instrument control panel.

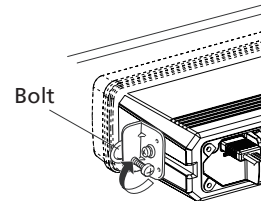

ANTENNA CONNECTION

Be sure to connect an antenna before transmitting. Select the antenna with the relative frequency and connect to the ANT antenna connector. Use the antenna and low loss concentric with the same natural impedance 50Ω . (See page 4 for more information.)

- Transmitting without an antenna may damage the transceiver.

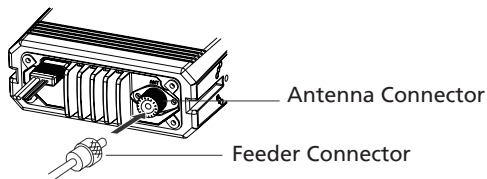

To The Antenna

CONNECTIONS

After connecting the DC power cable, GPS receiver lead and external speaker lead, cover the connector and leads with an adhesive tape as below, to prevent water entering the transceiver.



■ External speaker lead

Wiring details for an external speaker below.

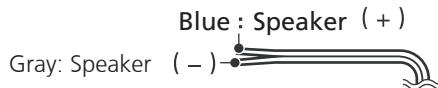

■ GPS receiver lead

Connect to a GPS receiver (sold separately) for position indication.

An NMEA0183 ver.2.0 or 3.01 (sentence formatters RMC, GGA, GNS, GLL) compatible GPS receiver is required.

Yellow : NMEA IN (+)

Green : NMEA IN (-)



■ DC power connector

Connect the supplied DC power cable to an external 13.8V DC power source. Do not connect to 24V storage battery.

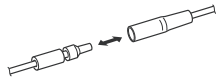

■ Fuse replacement

One fuse is installed in the supplied DC power cable. If the transceiver stops working, it is a good idea to check for a blown fuse. If the fuse is blown, replace the fuse with a new DC15A/32V fuse.

* Be sure to power off the unit before replacing the fuse.

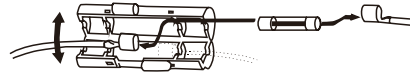

DIMENSIONS

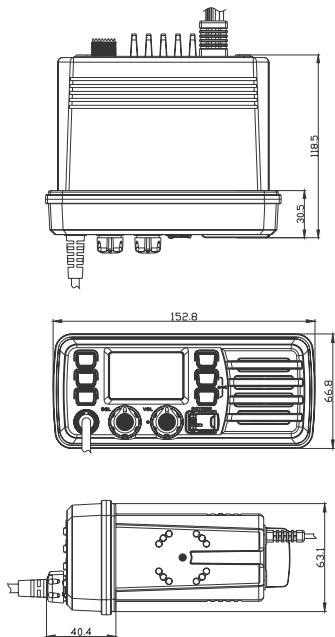

PANEL DESCRIPTION

FRONT PANEL

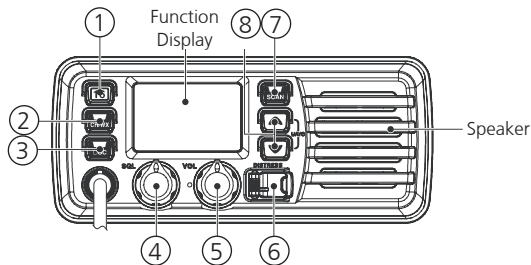

1. Channel 16 / Call Channel Key [16]

- Push to select Channel 16 (emergency channel).

- Push and hold for 1 sec. to select call channel.

“CALL” appears when the call channel is selected.

- While pushing and holding [CH/WX], push [16] to enter channel comments programming mode.

- Push to move the cursor backward.

- While turning power ON, push [16] to enter Set Mode.

2. Channel / Weather Channel Key

- Select and toggle between the regular channel and weather channel when pushed momentarily.

- Push and hold for 1 sec. to start Dualwatch or Tri-watch.

- Push and hold to stop Dualwatch or Tri-watch when either is activated.

- Push to move the cursor forward.

3. Digital Selective Calling (DSC)/Position Key - See page 27 for details.

- Push to enter DSC menu.

- Push and hold for 1 sec. to show the current position from a GPS receiver.

4. Squelch Control [SQL]

Rotate to set the squelch threshold level.

5. Power / Volume Control [VOL]

Rotate to turn the transceiver power ON and OFF and adjusts the audio level.

6. Distress Key [DISTRESS]

Push and hold for 5 sec. to transmit a Distress Signal.

7. Scan / Tag Key [SCAN]

- Push to start or stop the normal or priority scan.
- Push and hold for 1 sec. to set or clear the displayed channel as a TAG (scanned) channel.

The favorite channels are set by the TAG channel setting.

- Push and hold [HI/LO] and [SCAN] to clear all TAG channels in the selected channel group.

Repeat above procedure to set all TAG channels.

8. [▲][▼]/U/I/C (U.S.A/International/Canada)

- Select the proper operating channels, Set Mode settings, etc.
- While pushing and holding [SCAN], push [▲] or [▼] to adjust the brightness of the LCD and key backlight.

- Select one of three channel groups in sequence when both keys are pushed.
- While turning power ON, push and hold both keys to activate the WaterClean function.

MICROPHONE

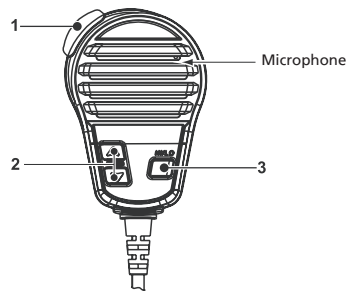

1. Push To Talk

Push and hold to transmit; release to receive.

2. Channel UP / DOWN Keys [▲]/[▼]

- Push either key to change the operating channel, Set Mode settings, etc.

- When the favorite channel function is turned ON, push either key to select the favorite channels in the selected channel group in sequence.

3. Transmit Power Key [HI/LO]

- Push to toggle the power between high and low.

Some channels can transmit in low power only.

- While pushing and holding [HI/LO], turn power ON to toggle the microphone lock function ON and OFF.

FUNCTION DISPLAY

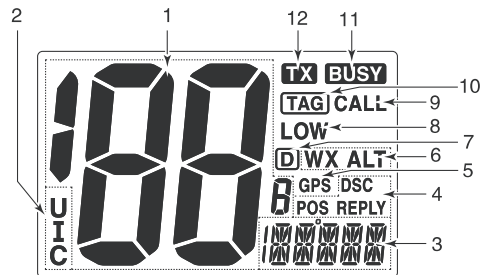

1. Channel Number Readout

- Indicates the selected operating channel number. (Refer to channel list)

- In Set Mode, indicate the selected condition.

2. Channel Group Indicator

Indicate whether a U.S.A. "U", International "I" or Canadian "C" channel is in use.

3. Channel Comment Indicator

- Channel comment appears if programmed.
- "LOW BATTERY" scrolls when the battery voltage drops below 10.8V DC.
- "SC" blinks during priority scan. "SCAN" blinks during normal scan.
- "DW" blinks during Dualwatch. "TW" blinks during Tri-watch.

4. DSC Indicators (Distress calls)

- "DSC" appears when a DSC call is received.
- "POS REPLY" appears when a position reply call or position report reply call is received.

5. GPS Indicator

- Appears while valid position data is received.
- Blinks when invalid position data is received.

- Disappears when no GPS receiver is connected.

6. Weather Channel Indicator

- "WX" appears when a weather channel is selected.
- "WX ALT" appears when the weather alert function is in use; blinks when an alert tone is received.

7. Duplex Indicator

Appears when a duplex channel is selected.

8. Low Power Indicator

Appears when low power is selected.

9. Call Channel Indicator

Appears when the call channel is selected.

10. TAG Channel Indicator

Appears when a TAG channel is selected.

11. Busy Indicator

Appears when receiving a signal or when the squelch opens.

12. Transmit Indicator

Appears while transmitting.

BASIC OPERATION

POWER ON / OFF

1. Rotate [VOL] clockwise to turn power on.
2. Rotate [VOL] counter-clockwise to turn power off.

RECEIVING AND TRANSMITTING

■ Transmitting

1. Push [HI/LO] on the microphone to select the output power if necessary.
 - "LOW" appears when low power is selected.
 - Choose low power for short range communication; choose high power for longer distance communication.
 - Some channels are for low power only.
2. Push and hold Push to talk (PTT) to transmit, then speak into the microphone.
 - "TX" appears.
 - Channel 70 cannot be used for anything other than DSC (distress alerts).
3. Release [PTT] to receive.

Note:

- Do not transmit before connecting the antenna as this can ruin the transceiver.
- The TOT (Time-out Timer) function inhibits continuous transmission over a preset time period after the transmission starts.

■ Receiving

1. Set the audio and squelch levels.
 2. Rotate [SQL] fully counterclockwise in advance.
 3. Rotate [VOL] to adjust the audio output level.
 4. Rotate [SQL] clockwise until the noise disappears.
- "When receiving a signal, [**BUSY**] appears and audio is emitted from the speaker.

CHANNEL GROUP SELECTION

The transceiver is pre-programmed with 59 U.S.A. and international channels and 63 Canadian channels. These channel groups may be specified for the operating area.

1. Push [CH/WX] to select a regular channel.
 - If a weather channel appears, push [CH/WX] again.
2. Push [U/I/C] (both [▲] and [▼] on the transceiver to change the channel group, if necessary.
 - U.S.A., International and Canadian channel groups can be selected in sequence.
3. Push [▲] or [▼] to select a channel.
 - [D] appears for duplex channels.

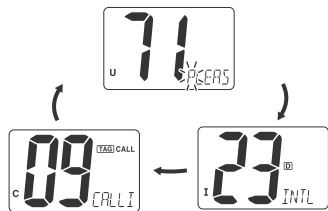

CHANNEL SELECTION

■ Channel 16

Channel 16 is the distress and safety channel. It is used for establishing initial contact with an aid station and for emergency communication. Channel 16 is monitored during both Dualwatch and Tri-watch. If you are not actively using your radio, you must monitor Channel 16.

1. Push [16] momentarily to select Channel 16.
2. Push [CH/WX] to return to the condition

before selecting Channel 16, or push [▲] or [▼] to select operating channel.



Convenient:

When the favorite channel function is turned ON, use the [▲]/[▼] keys on the microphone to select the favorite channels in the selected channel group.

- The favorite channels are set by the TAG channel setting. (Pg. 24)

■ Channel 9 (Call channel)

Each regular channel group has a separate leisure-use call channel (Channel 9, default).

The call channel is monitored during Tri-watch.

1. Push and hold [16] for 1 sec. to select the call channel of the selected channel group. "CALL" and the call channel number appears.
2. Push [CH/WX] to return to your previous call channel, or push [▲] or [▼] to select a channel.



■ Weather channels

The transceiver has 10 pre-programmed weather channels. The transceiver can automatically detect a weather alert tone on the selected weather channel while receiving the channel or during scanning.

1. Push [CH/WX] once or twice to select a weather channel.

- "WX" appears when a weather channel is selected.

- "WX ALT" appears when the weather alert function is in use.

2. Push [▲] or [▼] to select a channel.

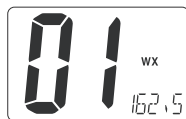

Weather Channel Alert is OFF.

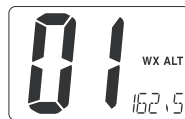

Weather Channel Alert is ON.

CALL CHANNEL PROGRAMMING

Call channel is used to select Channel 9 (default), however, you can program the call channel with your preferred channel in each channel group for quick recall.

1. Push [U/I/C] (both [▲] and [▼] on the transceiver several times to select the desired channel group (U.S.A., International or Canada) to be programmed.

2. Push and hold [16] for 1 sec. to select the call channel of the selected channel group.

- "CALL" and call channel number appear.

3. Push and hold [16] again for 3 seconds (until you hear long beep changes to 2 short beeps) to enter call channel programming condition.

- Channel number starts blinking.



4. Push [▲] or [▼] to select the desired channel.

5. Push [16] to program the displayed channel as the call channel.

- Push [CH/WX] to cancel.



CHANNEL COMMENTS

Channels stored in memory can be labeled with a unique alphanumeric ID of up to 10 characters each. Channel ID's with more than 6 characters automatically scroll after the channel is selected.

Capital letters, lower case letters (except f, j, k, p, s, v, x, z), 0 to 9, some symbols (= * + - . /) and space can be used.

1. Select the desired channel.
 - Cancel Dualwatch, Tri-watch or scan in advance.
2. While pushing [CH/WX], push [16] to edit the channel comment.
 - A cursor and the first character start blinking alternately.



3. Pushing [▲] or [▼] to select the desired character.
 - Push [16] or [CH/WX] to move the cursor forward or backward, respectively.
4. Repeat step **[3]** to input all characters.

5. Push [DSC] to input and set the comment.
 - Push [SCAN] to cancel.
 - The cursor and the character stop blinking.

MICROPHONE LOCK FUNCTION

The microphone lock function electrically locks [▲] and [▼] keys on the supplied microphone. This prevents accidental channel changes and function access.

- While pushing and holding [HI/LO] on the microphone, turn power ON to toggle the microphone lock function ON and OFF.

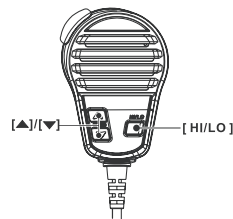

DISPLAY BACKLIGHTING

The function display and keys can be backlit for better visibility under low light conditions.

While pushing and holding [SCAN], push [▲] or [▼] to adjust the brightness of the LCD and key backlight.

- The backlight is selectable in 3 levels and OFF.

WATERCLEAN WATER DRAINING

WaterClean helps drain water away from the speaker housing (water that might otherwise muffle the sound coming from the speaker). The transceiver emits a vibrating noise when this function is being used.

1. While pushing and holding [▲] and [▼], turn power ON.

- "WATERCLEAN" appears.

2. A low beep tone sounds while [▲] or [▼] keys are held to drain water, regardless of [VOL] control setting.

- The transceiver never accepts a key operation while the WaterClean function is activated.



Scrolls

SCAN OPERATION

SCAN TYPES

The transceiver has priority scan and normal scan. (Refer to Set Mode programming).

When the weather alert function is turned ON, the previously selected (last used) weather channel is also checked while scanning.

Set the TAG channels (scanned channels) to create a list of channels to scan. Clear the TAG channels to eliminate unwanted TAG channels.

Normal scan:

Normal scan searches through all TAG channels in sequence. Channel 16 is not checked unless Channel 16 is set as a TAG channel.

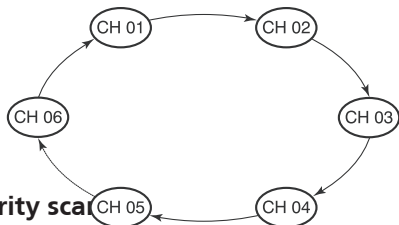

Priority scan

Priority scan searches through all TAG channels in sequence while monitoring Channel 16.

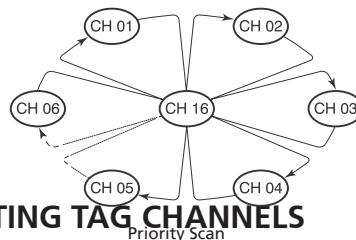

For more efficient scanning, add desired channels as TAG channels or clear the TAG to eliminate unwanted channels.

Channels that are not tagged will be skipped during scanning.

■ Setting / clearing a single tagged channel

1. Push [U/I/C] (both [▲] and [▼]) several times to select the desired channel group.

2. Select the desired channel to be set as a TAG channel.

3. Push and hold [SCAN] for 1 second to set the displayed channel as a TAG channel.

- “TAG” appears in the display.

4. To cancel the TAG channel setting, repeat step [3].

- “TAG” disappears.

■ Setting / clearing all tagged channels

1. While pushing and holding [HI/LO] on the microphone, push [SCAN] for 3 seconds to clear all TAG channels in the selected channel group.

2. Repeat above procedure to set all TAG channels.

■ Starting a scan

Set “Scan Resume Timer” in advance using Set Mode.

1. Push [SCAN] to start Priority or Normal scan.

- “SC” blinks during Priority Scan; “SCAN” blinks during Normal Scan.

- Channel 16 is monitored during Priority Scan.

- Push [▲] or [▼] to change the scanning direction.

- A beep tone sounds and “SC 16” blinks in the channel comment indicator when a signal is received on Channel 16 during Priority Scan.

2. To stop the scan, push [SCAN]

DUALWATCH / TRI - WATCH

DESCRIPTION

The transceiver has a Dualwatch and Tri-watch feature.

Dualwatch monitors Channel 16 while you are receiving on another channel.

Tri-watch monitors Channel 16 and another selected call channel while receiving another channel.

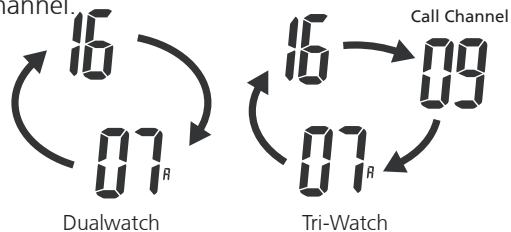

OPERATION

1. Select Dualwatch or Tri-watch in Set Mode.
2. Select the desired channel.
3. Push and hold [CH/WX] for 1 second to start Dualwatch or Tri-watch.
 - "DW" blinks during Dualwatch; "TW" blinks during Tri-watch.
 - A beep tone sounds when a signal is received on Channel 16.
4. To cancel Dualwatch or Tri-watch, push [CH/WX].

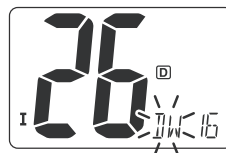

Dualwatch



Tri-Watch

DIGITAL SELECTIVE CALLING (DSC) OPERATION

MMSI CODE PROGRAMMING

Your 9-digit MMSI (Maritime Mobile Service Identity) is a number that identifies your boat. It can be programmed at Power ON.

1. Rotate [VOL] to turn power OFF.
2. While pushing and holding [DSC], turn power ON to enter MMSI code programming function.
3. After the display appears, release [DSC], and cursor starts blinking.



4. Edit the specified MMSI code by pushing [▲] or [▼].

- Push [16] or [CH/WX] to move the cursor forward or backward, respectively.

5. Input your 9-digit code, then push [DSC] to set the code.

- Returns to normal operation.

Note:

- This code programming can be performed only twice. After the code has been programmed, it can be changed only by your dealer or distributor.

MMSI CODE CHECK

The 9-digit MMSI (DSC self ID) code can be checked.

1. Push [DSC] to enter the DSC menu.
2. Push [▲] or [▼] to select “MMSI” and push [DSC].

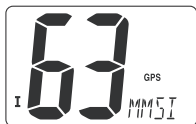

3. Check your 9-digit MMSI (DSC self ID) code.
 - The MMSI code is displayed and scrolls at the channel comment indicator.

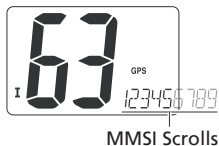

4. Push [DSC] to return to normal operation.

DSC ADDRESS ID

A total of 30 DSC address ID's (9-digit) can be programmed and named with up to 5 characters.

■ Programming Address ID

1. Push [DSC] to enter the DSC menu.
2. Push [▲] or [▼] to select “ADDRESS”, and push [DSC].



3. Push [▲] or [▼] to select “ADD”, and push [DSC].



4. Push [▲] or [▼] to input 9-digit of the appropriate Address ID.

- Push [16] or [CH/WX] to move the cursor forward or backward, respectively.

- Push [SCAN] to cancel and exit the condition.

Note: 1st digit "0" is fixed for a group ID. When you input 1st digit "0" and other 8 digits, the ID is automatically registered as a group ID.



5. After inputting 9-digit ID, push [DSC] to input 5 characters ID name using [▲] or [▼].

- Push [16] or [CH/WX] to move the cursor forward or backward, respectively.

- Push [SCAN] to cancel and exit the condition.

6. Push [DSC] to program and exit the DSC menu.

■ Deleting Address ID

1. Push [DSC] to enter the DSC menu.

2. Push [▲] or [▼] to select "ADDRESS" and push [DSC].



3. Push [▲] or [▼] to select "DEL", then push [DSC].

- When no Address ID is programmed, "NO ID" is displayed.



4. Push [▲] or [▼] to select the desired ID name for deleting and push [DSC], "READY" appears.



DISTRESS CALL

A Distress call should be transmitted if, in the opinion of the master, the ship or a person is in distress and requires immediate assistance.

Note: Never use the Distress call when your ship

or a person is not in an emergency. A Distress call should only be used when immediate help is needed.

■ Transmitting a Distress Call

1. While opening the key cover, push [DISTRESS] for 5 seconds to transmit the Distress call.

- Emergency channel (Channel 70) is automatically selected and the Distress call is transmitted.



2. After transmitting the call, the transceiver waits for an acknowledgment call on Channel 70.

- The Distress call is automatically transmitted about every 4 minutes.

- "DSC REPEAT" scrolls at the channel comment indicator.



3. After receiving the acknowledgment, reply using the microphone.

- "RCV DISTRESS ACK" scrolls at the channel comment indicator.

4. Push and hold [DISTRESS] for 5 sec. to transmit a new Distress call, if desired.

5. Push any key except [DISTRESS] to cancel 'Call Repeat' mode.

Note: A distress alert contains an undesigned distress signal:

- Position data: GPS position data held until receiving an 'acknowledgement'.

■ Receiving a Distress Call

While monitoring Channel 70 and a Distress call is received:

1. The emergency alarm sounds.

- Push any key to stop the alarm.

2. "DSC" appears and "RCV DISTRESS" scrolls at the channel comment indicator, then Channel 16 is automatically selected.

3. Continue monitoring Channel 16 as a coast station may require assistance.



■ Receiving a Distress acknowledgement

While monitoring Channel 70 and a Distress acknowledgement to other ship is received:

1. The emergency alarm sounds.

- Push any key to stop the alarm.

2. "DSC" appears and "RCV DISTRESS ACK" scrolls at the channel comment indicator, then Channel 16 is automatically selected.



■ Receiving a Distress Relay call

While monitoring Channel 70 and a Distress Relay acknowledgement is received:

1. The emergency alarm sounds.

- Push any key to stop the alarm.

2. "DSC" appears and "RCV RELAY" scrolls at the channel comment indicator, then Channel 16 is automatically selected.



INDIVIDUAL CALL

The Individual call function allows you to transmit a DSC signal to a specific ship only.

- Transmitting Individual call

1. Push [DSC] to enter the DSC menu.

- "INDIVIDUAL" scrolls at the channel comment indicator.



Scrolls

2. Push [DSC] to select the desired pre-programmed individual address using [▲] or [▼], then push [DSC].

- The ID code for the Individual call must be set in advance.



3. Push [▲] or [▼] to select a desired intership channel, then push [DSC].

- Intership channels are already preset into the transceiver in recommended order.

- Channel 70 is selected and "READY" appears after pushing [DSC].

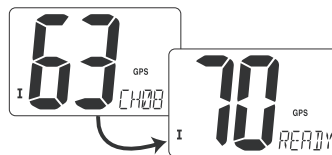

4. Push [DSC] to transmit the Individual call.

- If Channel 70 is busy, the transceiver stands by until the channel becomes clear.



5. After transmitting the Individual call, standby on Channel 70 until an acknowledgement is received.

- "WAIT ACK" scrolls at the channel comment indicator.



Scrolls

6. When the acknowledgement 'Able to comply' is received, the specified channel (in step **[3]**) is selected automatically with beeps. Or, when the acknowledgement 'Unable to comply' is received, the display returns to the operated channel (before entering the DSC menu) with beeps.

- "RCV ABLE ACK" OR "RCV UNABLE ACK" scrolls at the channel comment indicator.

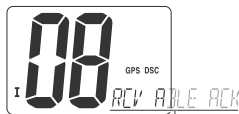

Scrolls

7. Push and hold [PTT] to communicate your message to the responding ship when 'Able to comply' is received.

■ Transmitting Individual Acknowledgement

When receiving an individual call, you can transmit an acknowledgement ('Able to comply' or 'Unable to comply') by using the on-screen prompts (refer to "Receiving an Individual Call"). You can also send an acknowledgement through the menu system as follows.

1. Push [DSC] to enter the DSC menu.
2. Push [▲] or [▼] to select "INDV ACK" and push [DSC].

- "INDV ACK" item appears after an Individual call is received.

- "INDV ACK" item disappears if another call is

received after the Individual call.

- The Individual Acknowledgement can be transmitted to the last received Individual call only.

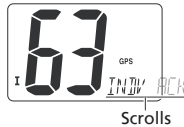

Scrolls

3. Push [▲] or [▼] to select the acknowledgement "ABLE" or "UNABL".



4. Push [DSC] to enter the standby condition for Individual acknowledgement call.

- "READY" appears at the channel comment indicator.



5. Push [DSC] to transmit the acknowledgement to the selected station.



6. After the Individual Acknowledgement has been transmitted, the display changes to the channel specified by the calling station automatically when "ABLE" is selected.



Scrolls

■ Receiving an Individual Call

While monitoring Channel 70 and an Individual Call is received:

1. The emergency alarm or beeps sound depending on the received category.
2. "DSC" appears and "RCV INDIVIDUAL" scrolls at the channel comment indicator.
3. Push any key to stop beeps.
4. Push [DSC] to reply to the call and select the channel specified by the calling station for voice communication. Push any other key to ignore the Individual call.



Scrolls

GROUP CALL

The Group Call function allows you to transmit a DSC signal to a specific group only.

■ Transmitting A Group Call

1. Push [DSC] to enter the DSC menu.
2. Push [▲] or [▼] to select "GROUP", and push [DSC].



3. Push [▲] or [▼] to select the desired pre-programmed group address, and push [DSC].

- The ID code for the Group call must be set in advance.



4. Push [▲] or [▼] to select the desired intership channel, and push [DSC].

- Channel 70 is selected and “READY” appears.

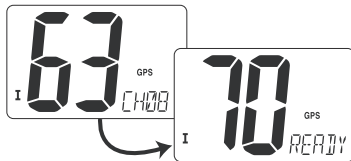

5. Push [DSC] to transmit the Group call.

- If Channel 70 is busy, the transceiver stands by until the channel become clear.

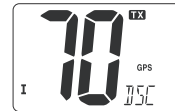

6. After the Group call has been transmitted, the display changes to the previously specified channel.



7. Push and hold [PTT] to communicate your message to the responding ship.

■ Receiving A Group Call

While monitoring Channel 70 and a Group Call is received:

1. The emergency alarm or beeps sound depending on the received category.

2. "DSC" appears and "RCV GROUP" scrolls at the channel comment indicator.
3. Push any key to stop beep.
4. Push [DSC] to select the channel specified by the calling station for voice communication; Push any other key to ignore the Group call.

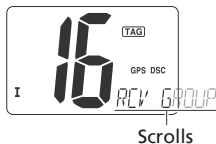

ALL SHIPS CALL

The All Ships Call function allows you to transmit a DSC signal to all ships.

■ Transmitting All Ships Call

Large ships use Channel 70 as their 'listening

channel'. When you want to announce a message to these ships, use the 'All Ships Call' function.

1. Push [DSC] to enter the DSC menu.
2. Push [▲] or [▼] to select "ALL SHIPS".



3. Push [DSC] to enter the standby condition for All Ships Call.

- Channel 70 is selected and "READY" appears.



4. Push [DSC] to transmit the All Ships Call.

- Low power is selected.



5. After the All Ships Call has been transmitted, the display changes to Channel 16 automatically.



■ Receiving an All Ships Call

While monitoring Channel 70 and a All Ships Call is received:

1. The emergency alarm sounds when the category is "Distress" or "Urgency". 2 beeps sound for other categories.

2. "DSC" appears and "RCV ALL SHIPS" scrolls at the channel comment indicator.

3. Push any key to stop beep.

4. Push [DSC] to monitor channel 16 for an announcement from the calling vessel, push any other key to ignore the call.



GEOGRAPHICAL AREA CALL

The Geographical Area Call function allows you to transmit a DSC signal to all ships in a geographical area.

■ Receiving a Geographical Area Call

While monitoring Channel 70 and a Geographical Area Call (for the area you are in):

1. The emergency alarm or beeps sound depending on the received category.
2. "DSC" appears and "RCV GEOGRAPHICAL" scrolls at the Channel Comment Indicator.
3. Push any key to stop the beep.
4. Push [DSC] to change to the channel specified by the calling station for voice communication. Push any other key to ignore

the Geographical Area Call.



POSITION INDICATION CALL

■ Positioning Instructions

When a GPS receiver is connected, the transceiver indicates the current position data in seconds of accuracy.

A NMEA0183 ver. 2.0 or 3.01 (sentence formatters RMC, GGA, GNS, GLL) compatible GPS receiver is required.

Push and hold [DSC] for 1 second to display the current position.

- 'Latitude' and 'Longitude' scroll in sequence at the channel comment indicator.
- "NO POSITION" scrolls when no GPS is connected.
- "GPS" blinks when the GPS data is invalid.

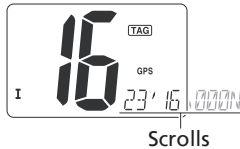

■ Transmitting Position Request Call

Transmit a Position Request Call when you want to know a specified ship's current position.

1. Push [DSC] to enter the DSC menu.
2. Push [▲] or [▼] to select "POS REQUEST", then push [DSC].

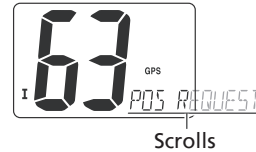

3. Push [▲] or [▼] to select the desired pre-programmed individual address.

- The ID code for position request must be set in advance.



4. Push [DSC] to enter the standby condition for Position Request Call.

- Channel 70 is selected and "READY" appears.



5. Push [DSC] to transmit the Position Request Call.



6. After the Position Request Call has been transmitted, the following indication is displayed.

- "WAIT ACK" scrolls at the Channel Comment Indicator.

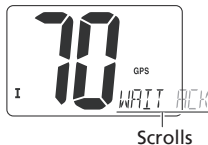

7. Push any key to exit the condition and return to the normal operation.

■ Transmitting Position Report call

Transmit a Position Report call when you want to announce your own position to a specific ship and to get an answer.

1. Push [DSC] to enter the DSC menu.
2. Push [▲] or [▼] to select "POS REPORT", and push [DSC].



3. Push [▲] or [▼] to select the desired pre-programmed individual address.

- The ID code for a Position Report Call can be

set in advance.



4. Push [DSC] to enter the standby condition for Position Report Call.

- Channel 70 is selected and "READY" appears.



5. Push [DSC] to transmit the Position Report Call.

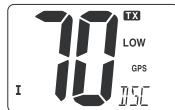

6. After the Position Report Call has been transmitted, stand by on Channel 70 until an acknowledgement is received.

- "WAIT ACK" scrolls at the Channel Comment Indicator.



Scrolls

7. Push any key to exit the function and return to the normal operation.

■ Receiving a Position Request Call

While monitoring Channel 70 and a Position Request Call is received:

1. "DSC" appears and "RCV POS REQUEST" scrolls at the Channel Comment Indicator.
2. Push any key to stop the beep.

3. Push [DSC] to reply to the call. Push any other key to ignore the call.

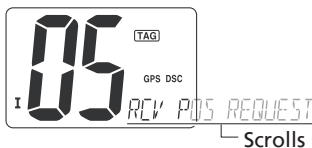

■ Receiving a Position Report Call

While monitoring Channel 70 and a Position Report call is received:

1. "DSC" appears and "RCV POS REPORT" scrolls at the Channel Comment Indicator.
2. Push any key to stop the beep.
3. Push [DSC] to reply to the call. Push any other key to ignore the call.

- The 'Latitude' and 'Longitude' from the called station is displayed and scrolled automatically

in order of Latitude coordinates and then Longitude coordinates.

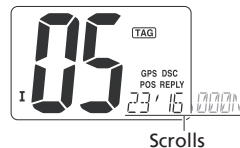

■ Receiving a Position Reply Call

While monitoring Channel 70 and a Position Reply Call is received:

1. "DSC" and "POS REPLY" appear in the display.
 - The 'Latitude' and 'Longitude' from the called station is displayed and scrolled automatically in order of Latitude coordinates and then Longitude coordinates.
2. Push any key to stop the beep.



■ Receiving a Position Report Reply Call

While monitoring Channel 70 and a Position Report Reply call is received:

1. "DSC" and "POS REPLY" appear in the display.
 - The 'Latitude' and 'Longitude' you have sent is displayed and scrolled automatically in order of Latitude coordinates and then Longitude coordinates.
2. Push any key to stop the beep.



SET MODE

SET MODE PROGRAMMING

Set Mode is used to change the conditions of the transceiver's functions: Scan Type (Normal or Priority), Scan Resume Timer, Weather Alert, Dual/Tri-watch, DSC Watch, Beep Tone, Auto Acknowledgement and Favorite Channel function.

Set Mode operation

1. Turn power OFF.
2. While pushing [16], turn power ON to enter Set Mode.
3. After the display appears, release [16].
 - "SCAN" appears at the Channel Comment Indicator.

4. Push [16] to select the desired item, if necessary.
5. Push [▲] or [▼] to select the desired condition of the item.
6. Turn power OFF, then ON again to exit Set Mode.

No.	Display	Item	Option	Default
1	SCAN	Scan type	n- (normal scan) / p- (priority scan)	n- (normal scan)
2	TIMER	Scan resume timer	of (OFF) / on (ON)	of (OFF)
3	WX ALERT	Weather alert	of (OFF) / on (ON)	of (OFF)
4	DUAL	Dual/Tri-watch	d-(Dualwatch) / t- (Tri-watch)	d-(Dualwatch)
5	DSC WATCH	DSC watch	of (OFF) / on (ON)	of (OFF)
6	BEEP	Beep tone	of (OFF) / on (ON)	on (ON)
7	AUTO ACK	Auto acknowledgement	of (OFF) / on (ON)	of (OFF)
8	FAVORITE CH	Favorite channel	of (OFF) / on (ON)	on (ON)

SET MODE ITEMS

■ Scan type

The transceiver has 2 scan types: Normal Scan and Priority Scan. Normal scan searches all TAG channels in the selected channel group. Priority scan searches all TAG channels in sequence while monitoring Channel 16.

■ Scan Resume Timer

The Scan Resume Timer can be selected as a pause (OFF) or timer scan (ON).

When OFF is selected, the scan pauses until the signal disappears. When ON is selected, the scan pauses 5 seconds and resumes even if a signal has been received on any other channel than Channel 16.

■ Weather alert

A NOAA broadcast station transmits a weather alert tone before important weather information. When the weather alert function is turned ON, the transceiver detects the alert, then the “WX ALT” indicator blinks until the transceiver is operated. The previously selected (used) weather channel is checked any time while scanning.

- “WX ALT” appears instead of “WX” indication when the function is set ON.

■ Dual / Tri-watch

This item can be selected as Dualwatch or Tri-watch.

■ DSC watch

DSC watch monitors Channel 70 while you are receiving another channel. If a distress signal

is received on Channel 70, the transceiver monitors Channel 16 and 70 alternately until the distress signal disappears. If a signal is received on another channel, DSC watch pauses until the signal disappears.

- This function may not be available for some channel groups depending on dealer setting.

- "DSC WATCH" scrolls at the channel comment indicator.

■ Beep tone

You can select silent operation by turning beep tones OFF or you can have confirmation beeps sound at the push of a key by turning beep tones ON.

■ Automatic acknowledgement

This item sets the Automatic Acknowledgement function ON or OFF.

When Position Request call or Position Report call is received, the transceiver automatically transmits Position Request Reply call or Position Report Reply call, respectively.

- "AUTO ACK" scrolls in the Channel Comment Indicator.

■ Favorite channel

This item sets the Favorite channel function ON or OFF.

The favorite channel is programmed by the TAG channel setting.

When the Favorite channel function is turned ON, the [▲] or [▼] keys on the microphone select the favorite channels in the selected channel group in sequence when pushed.

- "FAVORITE CH" scrolls in the Channel Comment Indicator.

SPECIFICATIONS

General	
Frequency coverage	TX: 156.025-157.425 MHz
	RX: 156.050 -163.275 MHz
Mode	FM (16K0G3E) DSC (16K0G2B)
Frequency stability	± 10ppm
Operating temperature range	-4°F (-20°C) ~ 140°F (+60°C)
Antenna impedance	50Ω
Dimensions (WxDxH)	6" (153mm) x 6" (152mm) x 2.6" (67mm)
Weight (main unit)	1.6 lbs (742g) w/microphone

Transmitter	
Output power	25W / 1W
Max. frequency deviation	±5.0 kHz
Spurious emissions	≤-70dB (H)
	≤-56dB (L)
Adjacent channel power	≥70dB
Audio harmonic distortion	≤10%
Current drain	≤5.5A (H)
	≤1.5A (L)
Input resistance	2kΩ

SPECIFICATIONS [continued]

Receiver	
Sensitivity	$\leq 0.2\mu\text{V}$
Squelch sensitivity	$\leq 0.2\mu\text{V}$
Adjacent channel selectivity	$\geq 70\text{dB}$
Spurious response rejection ratio	$\geq 70\text{dB}$
Intermodulation rejection ratio	$\geq 70\text{dB}$
Max. current	$\leq 1.5\text{A}$
Audio output power	$\geq 4.5\text{W}$ (10%)
GPS signal version	NMEA0183-2.0
Output impedance	4Ω

TROUBLESHOOTING

Issues described in the following table are common operational issues. These types of errors are generally due to improper connections, incorrect settings, or operator error due to incomplete programming. These problems are usually not caused by unit failure. Before suspecting radio failure, please refer to the relevant parts of this table and the solution instructions.

Question	Possible Cause	Solutions	Ref. page
Power did not respond.	1. The power cable is not connected well.	1. Be sure the power cable is connected correctly: red (+); black (-).	10
	2. The power cable fuse is blown.	2. Find the cause of blown fuse, then replace with a DC15A/32V fuse.	11
	3. The voltage exceeds 17V or below 9V.	3. Be sure the adjust the power supply is 13.8V.	1
Unable to connect with GPS.	1. Connection error.	1. Be sure the check the connections are correct.	11
	2. Different external GPS format.	2. External GPS format should be NMEA0183-2.0.	11
Can not scan.	No set mark channels (TAG).	Set the channel you want to scan to mark channels.	23-26

TROUBLESHOOTING [continued]

Question	Possible Cause	Solutions	Ref. page
Can not transmit.	Channel set to weather channel or 70 channels.	Exit the weather channel or 70 channels.	20
High power can not be selected.	Some channels can only transmit at low power.	Choose another channel.	17
Radios on the same channel can not talk.	1. The channel is different frequency.	1. Select another channel with the same frequency. 2. Set the current channel to the same frequency.	18 49
No beep	Beep off	Open the beep function in the settings mode.	48
Can not transmit a distress call.	MMSI code is not set.	Hold down the [DSC] key to boot into MMSI setting mode.	27
No sound from the speaker.	1. Squelch level too high. 2. Volume level too low. 3. Speaker has been exposed to water.	1. Rotate [SQL] knob to adjust the squelch level. 2. Rotate [VOL] knob to adjust the volume. 3. Remove water with WaterClean function.	18 18 23

WARRANTY STATEMENT

RCA Communications Systems warrants each new radio product it supplies to be free from defects in material and workmanship under normal use and service for the time period listed below, provided that the user has complied with the requirements stated herein.

The warranty period begins on the date of purchase from an Authorized RCA Communications Systems Sales and Service Outlet. This warranty is offered to the original end user and is not assignable or transferable. RCA Communications Systems is not responsible for any ancillary equipment which is attached to or used in conjunction with RCA Communications Systems products.

RCA Communications Systems offers to the original end user a Two (2) Year Limited Warranty on the RCA MRM400™ Radio Handset.

During this period, if the product fails to function under normal use because of manufacturing defect(s) or workmanship, it should be returned to the Authorized RCA Communications Systems Sales and Service Outlet from which it was purchased. The Sales and Service Outlet will repair the product to full operating specifications or replace the product with a new product of the same make and model. The user is responsible for all charges incurred in returning the product to the Authorized RCA Communications Systems Sales and Service Outlet. RCA Communications Systems will be responsible for all charges in returning the product to the end user via standard ground shipping service.

RCA Communications Systems shall have no obligation to repair or replace the product, if there

is damage as a result of normal wear and tear or if the damage is caused in whole or in part by catastrophe, fault or negligence of the user, improper or unauthorized alterations or repairs to the product, incorrect wiring, use of the product in a manner for which it was not designed, or by causes external to the product. This warranty is void if the product serial number is altered, defaced or removed.

THE EXPRESS WARRANTIES CONTAINED HEREIN ARE IN LIEU OF ALL OTHER WARRANTIES, EITHER EXPRESSED OR IMPLIED OR STATUTORY, INCLUDING, WITHOUT LIMITATION, ANY WARRANTY OF MERCHANTABILITY OR FITNESS FOR A PARTICULAR PURPOSE.

FOR ANY PRODUCT WHICH DOES NOT COMPLY WITH THE WARRANTY SPECIFIED, THE SOLE REMEDY WILL BE REPAIR OR REPLACEMENT. IN NO EVENT WILL RCA COMMUNICATIONS SYSTEMS BE LIABLE TO THE BUYER OR ITS CUSTOMERS FOR ANY DAMAGES, INCLUDING ANY SPECIAL, INCIDENTAL, INDIRECT OR CONSEQUENTIAL DAMAGES, OR THE LOSS OF PROFIT, REVENUE OR DATA ARISING OUT OF THE USE OR THE INABILITY TO USE THE PRODUCT.

RCA Communications Systems endeavors to make this manual accurate and complete, but is not liable for any possible omission and printing mistakes.

All specifications and designs are subject to change without prior notice.

All the reproduction and translation of this manual without authorization is prohibited.

No part of this manual may be copied, reproduced, translated, stored in a retrieval system, distributed, or transmitted in any form or by any means, electronic or mechanical, for any purpose without the expressed, written permission from RCA Communications Systems.

The end-user of any two-way radio is solely responsible for obtaining any license or other authorizations required by the Federal Communications Commission (FCC). For further information visit www.fcc.gov or call 1-888-CALL-FCC (1-888-225-5322).

NOTES:

For Sales, Warranty and Customer Support please contact:
Discount Two-Way Radio Corporation – North American Distributor
555 W Victoria Street
Rancho Dominguez, CA 90220
Phone: 310-224-5100 / Fax: 310-224-5101
www.discounttwo-wayradio.com